

# L'shape range

## Internal gear

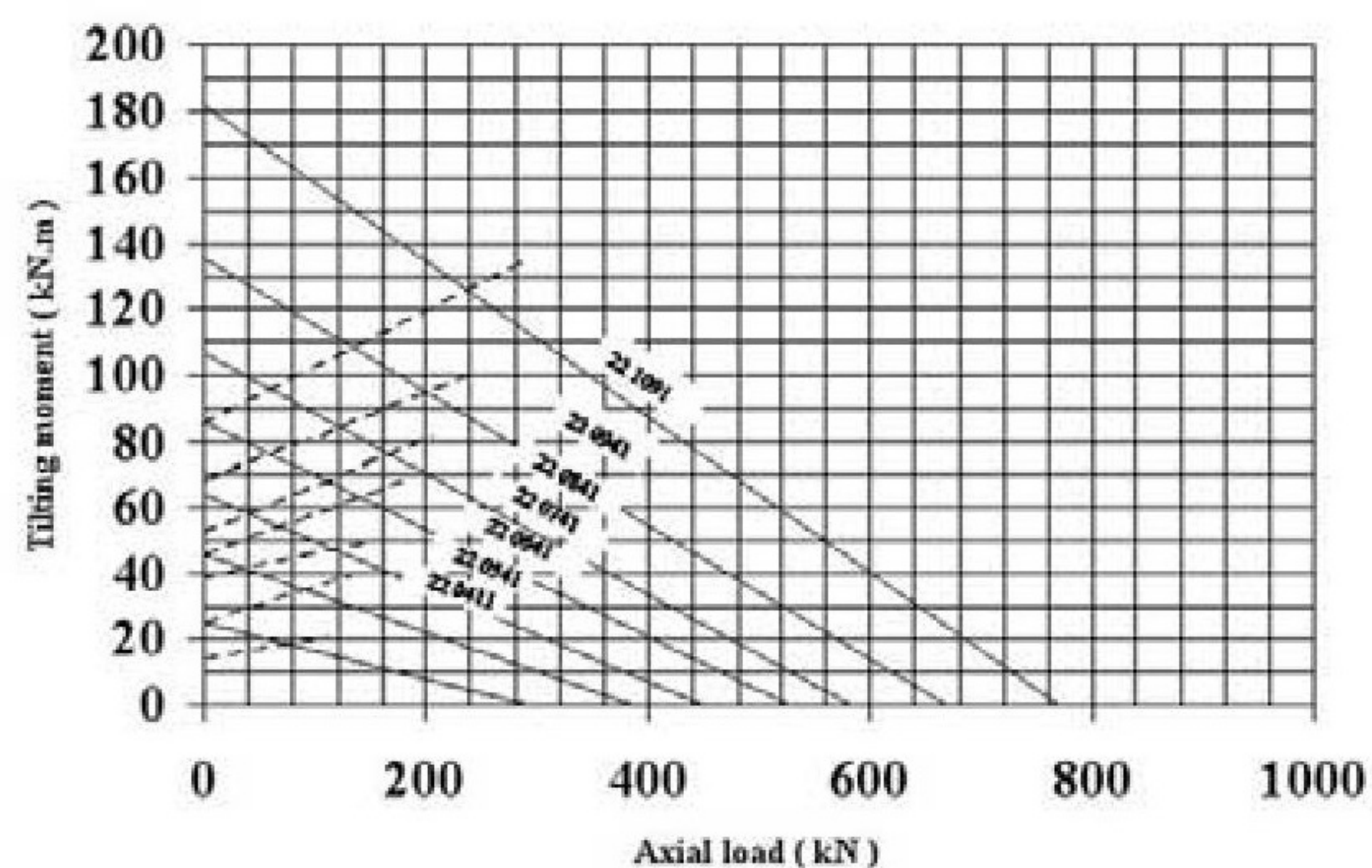
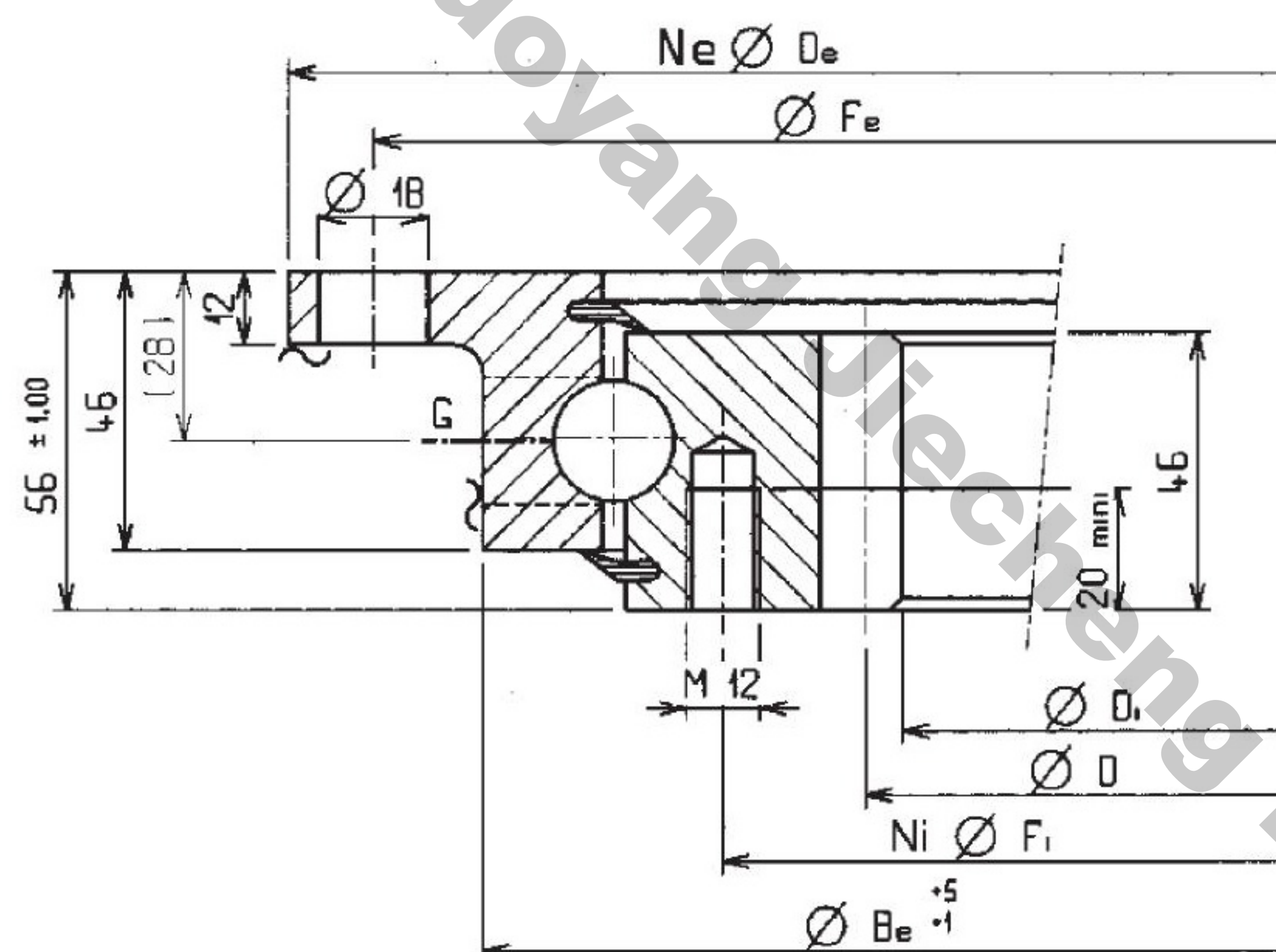

Main dimensions			Fixing holes				Gear teeth			Permissible tangential load maxi	Mass	Designation
De	Di	Bi	Fe	Ne	Fi	Ni	m	z	D	Kn	kg	
mm	mm	mm	mm		mm				mm			
518	325	454	490	8	375	12	5	67	335	32,4	31	RKS.22 0411
648	445	584	620	10	505	16	6	76	456	40,3	41	RKS.22 0541
748	546	684	720	12	605	18	6	93	558	40,3	48	RKS.22 0641
848	649	784	820	12	705	20	6	110	660	40,3	55	RKS.22 0741
948	736	884	920	14	805	20	8	94	752	54,3	63	RKS.22 0841
1048	840	984	1020	16	905	22	8	107	856	54,3	71	RKS.22 0941
1198	986	134	1170	16	1055	24	8	125	1000	54,3	80	RKS.22 1091